

**HERRAMIENTAS PARA
ALUMINIO**

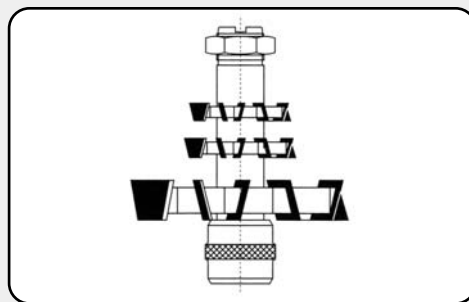

HERRAMIENTAS PARA CORTE DE ALUMINIO

LEAIZ dispone de discos de alta calidad para corte de aluminio.

El corte de los perfiles de aluminio en recto o en inglete es uno de los apartados mas importantes en el proceso de fabricación de ventanas.



INGLETADORA MANUAL ANG. NEGATIVO 5°

D	B/b	d	Z	P	S43	N02EA
					Código ECO	Código GAMA ALTA
250	3.2/2.4	30	80	2/8/45	S43BA080	N02EAM101GS
250	3.2/2.4	32	80	2/8/45	S43BA081	N02EAM101HS
275	3.2/2.4	20	84		-	N02EAM101JS
300	3.2/2.4	30	96	2/11/63	S43BC096	N02EAM101KS
300	3.2/2.4	32	96	2/11/63	S43BC962	N02EAM101LS
330	3.6/2.8	30	104	2/11/63	-	N02EAM101MS
350	3.6/2.8	30	108	2/11/63	S43BE108	N02EAM101NS
350	3.6/2.8	32	108	2/11/63	S43BE1082	N02EAM101OS
370	4.0/3.2	30	116	2/11/63	-	N02EAM101PS
400	4.0/3.2	30	120	2/11/63	S43BF120	N02EAM101QS
400	4.0/3.2	32	120	2/11/63	S43BF122	N02EAM101RS
400	4.0/3.2	50	120	2/15/80	-	N02EAM101SS

INGLETADORAS DE DOBLE CABEZAL

Perfiles de espesor menor de 4 mm.

05EAM10 - Angulo Positivo 5°

D	B/b	d	Z	P	05EA
					Código G. ALTA
400	4.0/3.2	30	120	2/11/63	05EAM101AS
400	4.0/3.2	32	120	2/11/63	05EAM101BS
420	4.0/3.2	30	132	2/11/63	05EAM101CS
450	4.0/3.2	30	144	2/11/63	05EAM101DS
450	4.0/3.2	32	144	2/11/63	05EAM101ES
500	4.0/3.2	30	160	2/11/63	05EAM101FS
500	4.0/3.2	32	160	2/11/63	05EAM101GS
500	4.0/3.2	50	160	2/15/80	05EAM101HS
530	4.2/3.4	30	150		05EAM101IS
550	4.2/3.4	30	160		05EAM101JS
600	4.4/3.4	30	176		05EAM101KS

Perfiles de espesor mayor de 4 mm.

05EAM13 - Angulo Positivo 5°

D	B/b	d	Z	P	S44	05EA
					Código ECO	Código G. ALTA
400	4.0/3.2	30	96	2/11/63	S44BF096	05EAM131AS
400	4.0/3.2	32	96	2/11/63	S44CF096	05EAM131BS
420	4.0/3.2	30	100	2/11/63	S44BG096	05EAM131CS
450	4.0/3.2	30	108	2/11/63	S44BH108	05EAM131DS
450	4.0/3.2	32	108	2/11/63	S44BJ108	05EAM131ES
500	4.0/3.2	30	120	2/11/63	S44BI120	05EAM131FS
500	4.0/3.2	32	120	2/11/63	S44BK120	05EAM131GS
500	4.0/3.2	50	120	2/15/80	-	05EAM131HS
550	4.4/3.4	30	132		-	05EAM131IS
600	4.4/3.4	30	144		-	05EAM131JS
650	4.4/3.4	40	160		-	05EAM131KS

25AC - ANILLAS DE SEPARACION

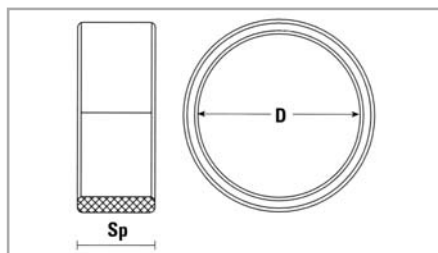

Código	Ext.	D	Sp
A25JK10	38	32	1
A25JK15	38	32	1.5
A25JK20	38	32	2
A25JK25	38	32	2.5
A25JK30	38	32	3
A25JK35	38	32	3.5
A25JK40	38	32	4
A25JK45	38	32	4.5
A25JK50	38	32	5
A25JK60	38	32	6
A25JK80	38	32	8
A25JK100	38	32	10
A25JK110	38	32	11
A25JK115	38	32	11.5

Código	Ext.	D	Sp
A25JK120	38	32	12
A25JK125	38	32	12.5
A25JK130	38	32	13
A25JK135	38	32	13.5
A25JK150	38	32	15
A25JK190	38	32	19
A25JK230	38	32	23
A25JK250	38	32	25
A25JK300	38	32	30
A25JK350	38	32	35
A25JK400	38	32	40
A25JK500	38	32	50
A25JK600	38	32	60

CASQUILLOS PORTAFRESAS PARA MAQ. CON CAMBIO RAPIDO

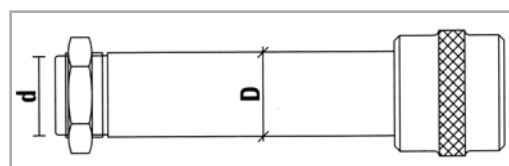
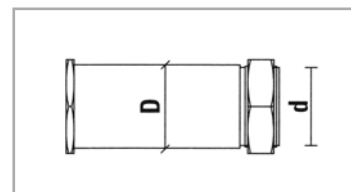

JGO - JUEGOS DE FRESAS

Precios válidos para juegos de fresas estandar.

Código	Nº. DE FRESAS
JAF3E	Juego de 3 fresas
JAF4E	Juego de 4 fresas
JAF5E	Juego de 5 fresas

Para otros juegos (con planos inclinados, curvos, ...) o distinto número de fresas; **consúltenos.**

Los juegos de fresas **NO incluyen eje portafresas.**

80AC - EJES PORTAFRESAS

Código	Maquina	Medidas
A80C02	Tipos varios	22*32*80
A80C03	Tipos varios	27*32*80
A80C04	Tipos varios	27*32*110
A80C05	Rinaldi10B / Pertici ML120 / 3C 2500	27*32*100
A80C06	Rinaldi 9A / Omgá AL132 / Pertici ML124	27*32*135
A80C07	Giovannini Work / 3C 3000	27*32*135
A80C08	Rinaldi 350DS / 3C 3500	27*32*160
A80C09	Mecal 706 - 702 - 703	27*32*150
A80C11	Comall con relulación	27*32*120
A80C15	FOM jet / Mistral / Marak	25*32*168
A80C20	Omc Feroce	27*32*134
A80C22	Mepal 711	25*32*162
A80C23	Tronzadoras MG / Rafre	27*32*142
A80C24	Ayutor	21*32*95
A80C25	Tekna TK610	27*32*140
A80C26	Mekal 701 / Madaf	27*32*155
A80C27	Tipos varios	27*32*130
A80C28	Mecal / Simo / Ciao	12*32*155

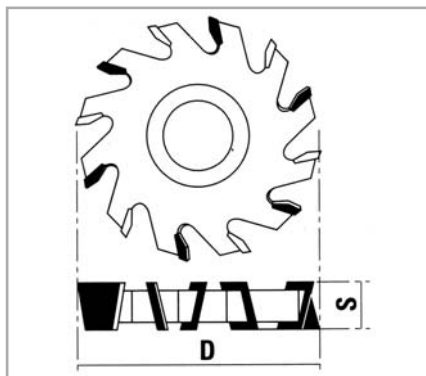

FRESAS DE DIENTES ALTERNOS MD

Mejor capacidad de corte en comparación a las fresas de diente recto.

- SE FABRICA BAJO PEDIDO

- PARA OFERTAR ES PRECISO INDICAR TIPO DE PERFIL.

06FR

FRESAS PARA RETESTADORA DE ALUMINIO

Código	Diámetro	Eje	Espesor	Dientes
F07005	70	32	5	8
F07006	70	32	6	8
F07008	70	32	8	8
F07105	71	32	5	8
F07204	72	32	4	8
F07205	72	32	5	8
F07206	72	32	6	8
F07207	72	32	7	8
F07208	72	32	8	8
F07405	74	32	5	8
F07406	74	32	6	8
F07505	75	32	5	8
F07506	75	32	6	8
F07605	76	32	5	8
F07606	76	32	6	8
F07607	76	32	7	8
F07675	76	32	7.5	8
F10005	100	32	5	10
F10006	100	32	6	10
F10008	100	32	8	10
F11005	110	32	5	12
F11006	110	32	6	12
F11205	112	32	5	12
F11206	112	32	6	12
F11405	114	32	5	12
F11406	114	32	6	12
F11408	114	32	8	12
F11606	116	32	6	12

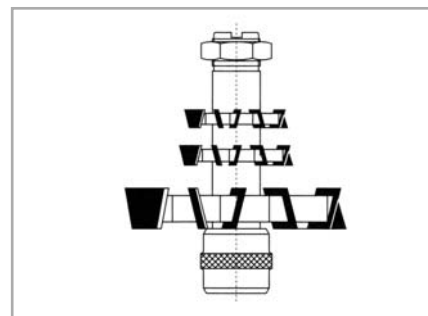
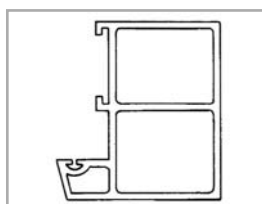
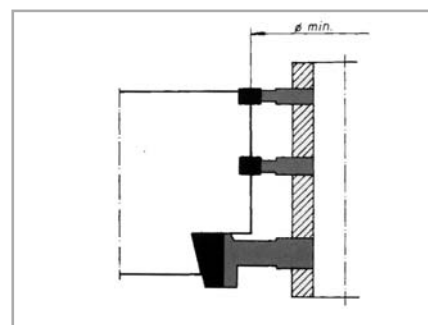

Para otros juegos (con planos inclinados, curvos, ...) o distinto número de fresas; **consúltenos.**

60FM **FRESOLINES HSS Z1 (ALUMINIO Y PVC)**

Código	D	L1/L2	L	Z	d
A6005A	5	13	60	1	8
A6005B	5	14/35	80	1	8
A6006A	6	15	60	1	8
A6006B	6	15/45	90	1	8
A6008A	8	15	80	1	8
A6008B	8	14/70	100	1	8
A6008C	8	14/76	120	1	8
A6010A	10	15	80	1	10
A6010B	10	14/80	120	1	10

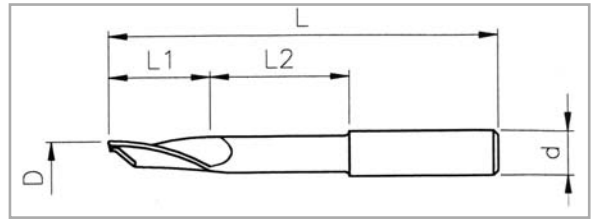

Para otras medidas o calidades consultar.

Para ACERO NORMAL e INOXIDABLE,
consultar precios.
Se suministrarán bajo demanda en Z=3 y Z=4.



30BH - BROCA HERRAJE MD

Código	D	L	Z	Mango
A3557	35	57.5	2	10

